

Associated British Ports

PLANT HIRERS INDEMNITY

In consideration of Associated British Ports at our request permitting us to carry out any operations connected with the business of ourselves, our customers, servants and agents at any of the ABP's premises at Lowestoft we hereby undertake to bear the risk of and to be responsible for and to release and indemnify Associated British Ports their servants and agents from and against all liability for personal injury (whether fatal or otherwise) save to the extent that Section 2(1) of the Unfair Contract Terms Act 1977 shall be applicable loss of or damage to property and any other loss damage costs and expenses however caused (save to the extent that the same may be caused by the negligence of Associated British Ports, its servants or Agents) and which but for the exercise of the said permission would not have arisen.

It is agreed that entry into the Port Estate shall also be subject to ABP's Standard Terms and Conditions of Trade currently in force (which are available on request) and we have been advised that these Terms include provisions inter alia relating to any acceptance of liability by ABP including a monetary limit on such liability.

Witness to the Signature of _____ Signature _____

Dated this _____ day of _____ 20_____

Firm _____

Address _____

Dated this _____ day of _____ 20 _____

ABP PORT OF LOWESTOFT
APPLICATION TO OPERATE A MOBILE CRANE

MOBILE CRANE LIFT

Please return completed application to the Port Control
Tel: +44 (0)1502 572286 Mob: +44 (0)7771 605520

General Details

Name of Applicant	
Address	
Name of Contact	
Tel	
Fax	
Mobile	

Date of application	
Name of Vessel	
Preferred Berth	
Date of lift operation	

Name of appointed licensed stevedore / Person	
---	--

Name of designated Lift Co-ordinator	
Organisation	
Address	
Tel	
Fax	
Mobile	

Description of lift	
Dimensions of lift	

Risk assessment and Safe System of Work covering lift operation and all other mobilisation / demobilisation / delivery / forwarding operations completed	Yes / No*
ABP Safety code SC2 reviewed and incorporated into Safe System of Work	Yes / No*
Completed Crane Indemnity form enclosed	Yes / No*
Details of delivery / forwarding transport enclosed	Yes / No*

Crane Details

Crane make and model	
Weight of crane (tonnes)	
Weight of lift (tonnes)	
Maximum radius of lift (m)	
Crane capacity at lift radius (tonnes)	
Maximum radius of crane (m)	
Maximum capacity at maximum radius of crane (tonnes)	
Are pads proprietary crane manufacturer supplied equipment	Yes / No
If No please provide description of pads (steel / timber / thickness etc)	
The following pad load information is based upon -	the maximum lift capacity of the crane or the actual load being lifted*

*Delete as appropriate

Pad Loadings

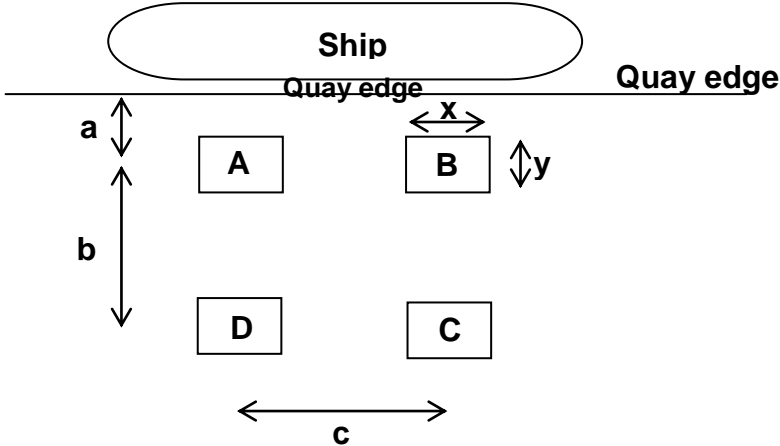

Pad	x(m)	y(m)
A		
B		
C		
D		

Dim	(m)
a	
b	
c	

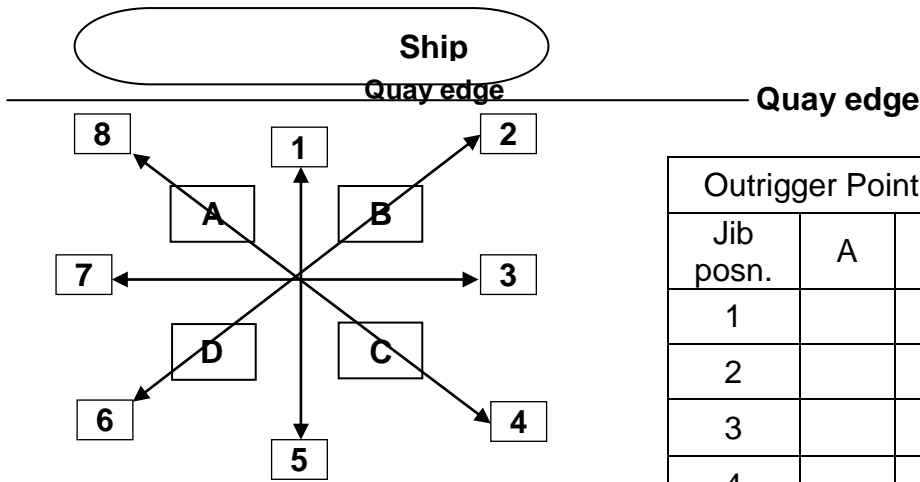

Jib posn.	A	B	C	D
1				
2				
3				
4				
5				
6				
7				
8				

Applicant	
Signed	Print Name

ABP Comments

----- ✂ ----- ✂ -----

ABP PORT OF LOWESTOFT

ABP OPERATIONS DEPT USE ONLY

Completed form must be handed to a member of staff at the Port Office prior to commencement of any work using mobile crane that requires further information above the **'Mobile Crane Quay Loading Lowestoft'** document.

Authorisation for entry of mobile crane to be used at :

Destination / Vessel : _____ on ____ / ____ /20

Authorised by ABP: _____ Date : ____ / ____ /20



MOBILE CRANE (80TON) QUAY LOADINGS LOWESTOFT

Quay	Maximum Loading	Minimum Distance of Outrigger Pad From Quay Edge	Minimum Distance Between Point Loads
Waveney 1 & 2.	12 t / sq.m	3.5 metres	At least... 3.5 metres
Silo Quay	12 t / sq.m	3.5 metres	At least... 3.5 metres
Town Quay	12 t / sq.m	Pad on concrete capping	At least... 3.5 metres
NQCT / Nth Quay West	12 t / sq.m	3.5 metres	At least... 3.5 metres
Nth Quay East (Suspended Quay)	12 t / sq.m	7.5 metres	At least... 3.5 metres
Trawl Dock (Suspended Quay)	12 t / sq.m	11 metres	At least... 3.5 metres
Hamilton / Waveney Dock	12 t / sq.m	5 metres	At least... 3.5 metres
School Rd.	2.9t / sq.m	3.5 metres	At least... 3.5 metres

*NOTED EXCEPTION – SCHOOL ROAD ONLY for small general mobile cranes with :-

- ⇒ a confirmed outrigger load NOT exceeding 14T must be at least 2metres from the Quay edge to the centre of a 1.0m square outrigger pad.
- ⇒ a confirmed outrigger load NOT exceeding 5T must be at least 1metres from the Quay edge to the centre of a 1.0m square outrigger pad.